

# COHU, INC. Electronics Division

## Installation and Operation Instructions

### 1100 SERIES RS-170 AND CCIR MONOCHROME CAMERAS

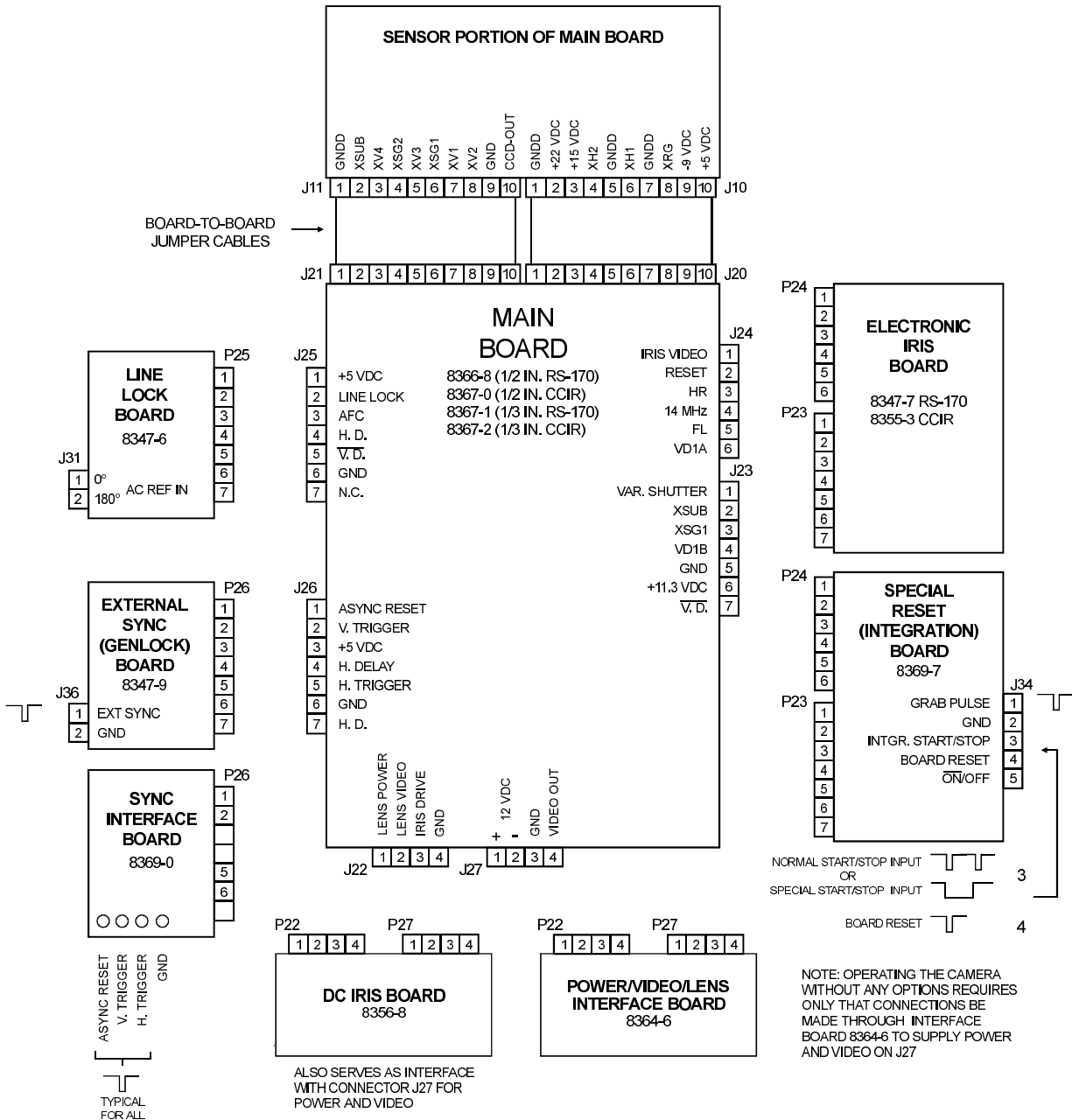

12367 CROSTHWAITE CIRCLE POWAY, CA 92064  
 PHONE (619) 277-6700 FAX (619) 277-0221 INFO@COHU.COM

**COHU**  
 CoHu, Inc./Electronics Division

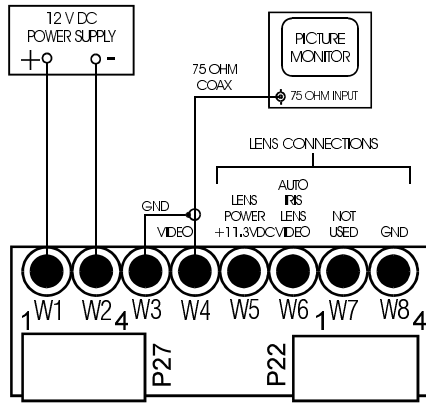

W1-4 interface to pins P27-1 to -4  
W5-8 interface to pins P22-1 to -4

**EQUIPMENT SUPPLIED**

The following list does not include any optional or special-request items.

1. Camera, 1100 series, and 8364-6 power/video interface board
2. Manual, Installation and Operation 6X-970(B)

**EQUIPMENT REQUIRED BUT NOT SUPPLIED**

1. Power supply, 12 V dc, 300 mA (with a 12V ac output if the line lock option is being used)
2. Adapter, CS-mount (Option)\*
3. Adapter, C-mount (Consists of a 5 mm extension ring and a CS- mount) [Option]\*
4. Lens, TV type, CS-mount or C-mount. (When using the optional electronic iris circuit, a manual iris lens is required)
5. Monitor, RS-170 or CCIR, as required
6. Cables (video, power input, external sync, and others depending on the options and desired applications)
7. Available option boards:
  - Sync interface board
  - External sync (genlock) board
  - Electronic iris board
  - Linelock board
  - Dc iris board
  - Special reset (integration) board

\*Includes a set screw (4-40 x 5/32) and hex wrench (0.050)

**S1 SWITCH SETTINGS**

SHUTTER SPEED	S1-1	S1-2	S1-3	S1-4	S1-5
OFF	•				
1/100 (NTSC)	Flickerless Mode				
1/120 (CCIR)				•	•
1/125			•		•
1/250		•			•
1/500		•	•		•
1/1000	•				•
1/2000	•		•		•
1/4000	•	•			•
1/10,000	•	•	•		•
FIELDS	S1-1	S1-2	S1-3	S1-4	S1-5
(Settings from 2 to 16 available in field mode only)					
2				•	
4			•	•	
6		•		•	
8		•	•	•	
10	•			•	
12	•		•	•	
14	•	•		•	
16	•	•	•	•	

NOTES:  
• = ON; All others OFF

For S1-6, ON = FIELD MODE; OFF = FRAME MODE

Flickerless mode eliminates interference with ac power line lighting when a 60 Hz camera is used with 50 Hz lighting or a 50 Hz camera with 60 Hz lighting.

When using either the optional electronic iris board or optional special reset board the 1/10,000 shutter mode must be selected

**CAUTION**

Be sure to maintain the correct pin to pin connections when plugging in the flexible jumper cables between the sensor board and the main board. Failure to do so will damage the camera. Refer to the figure on page 1. Also, replace the cable in the same orientation as when it was removed.

**CONNECTOR J22 (AUTO IRIS LENS) PIN FUNCTIONS**

PIN NO.	NAME	INPUT / OUTPUT	FUNCTION
1	Lens Power	Output	Provides 11.3 V dc, 100 mA (maximum), for use by auto-iris lenses having their own internal driver board
2	Lens Video Out	Output	Provides a low impedance, buffered, dc-isolated ac output signal related to video level for operation of an auto-iris lens that has its own driver board
3	Iris Video	Output	Signal used by the dc iris option board
4	Ground	-	Common for all other pins on the connector

**CONNECTOR J26 (SYNC INPUT) PIN FUNCTIONS**

PIN NO.	NAME	INPUT/ OUTPUT	FUNCTION
1	Async Reset / Special Reset	Input	The input for asynchronously resetting the camera sync generator.
2	Vertical Trigger	Input	The input for a vertical trigger pulse when the camera is being synchronized to externally applied horizontal (pin 5) and vertical pulses
3	+5 D	Output	Provides 5 V dc for use by the optional external sync (genlock) board
4	H. Delay	—	Circuit function implemented by an option board
5	Horizontal Trigger	Input	An input for horizontal trigger pulses when the camera is being synchronized to externally applied horizontal and vertical (pin 2) pulses
6	Ground D	—	A grounded pin for signals

**CONNECTOR J27 (POWER IN/VIDEO OUT) PIN FUNCTIONS**

PIN NO.	NAME	INPUT/ OUTPUT	FUNCTION
1	12 V dc (+)	Input	A 12 V dc $\pm$ 10 percent source of operating power for the camera
2	12 V dc (Common)	—	Ground. Provides connection for the input power common lead.
3	Ground	—	Provides common line for the video signal
4	Video	Output	Provides the 75-ohm, 1-Vp-p video output signal from the camera for connection to a tv monitor or similar equipment

Note: Page 1 shows two circuit boards that can be used as an interface when connecting to J27

**CONNECTOR J34 (INTEGRATION) PIN FUNCTIONS**

PIN NO.	NAME	INPUT/ OUTPUT	FUNCTION
1	Grab Pulse	Output	Provide an output pulse of either positive or negative going polarity (jumper selectable) to sync a frame grabber with the integrated output video
2	Ground	—	Signal common line
3	Integration Begin/End	Input	Accepts input pulses to control the beginning and ending of integration by the sensor. Two types of inputs are jumper selectable: (1) Start/Stop Mode/ Integration is initiated by the negative-going leading edge of one pulse and stopped by the negative-going leading edge of a second pulse, or (2) Special Reset Mode/ the negative-going edge of a pulse begins integration and the subsequent positive-going edge of that same pulse ends the integration.
4	Reset	Input	Initializes the special reset board
5	On(low)/ Off (high)	Input	Turns the special reset board on or off (If this board is to be turned on, shuttering switch must be set to 1/10,000)

Note: Use of the integration board requires that a frame grabber be connected to the camera. A frame grabber captures the single field/frame of the integrated video supplied at the camera video output. This video is digitally stored by the frame grabber to make it available for use. (Observing the video output with a standard monitor — and no frame grabber — produces the following result when integrating: First, 1/10,000 second shuttering must be established and field or frame mode selected. Then the special reset (integration) board must be turned on (pin 5 low). When integration is initiated (pin 3) the picture on the monitor will go black or very dark. At the end of the integrator period a single field/frame of the integrated video will “flash” on the monitor. After this field/frame appears, the output of the camera returns to a normal picture, which is being shuttered at 1/10,000 second.)

See page 6 for input and output waveforms related to J34

**CONNECTOR J36 (GENLOCK INPUT) PIN FUNCTIONS**

PIN NO.	NAME	INPUT/ OUTPUT	FUNCTION
1	Genlock	Input	Provides an input for genlocking the camera to either composite video or composite sync
2	Ground	—	Signal common line

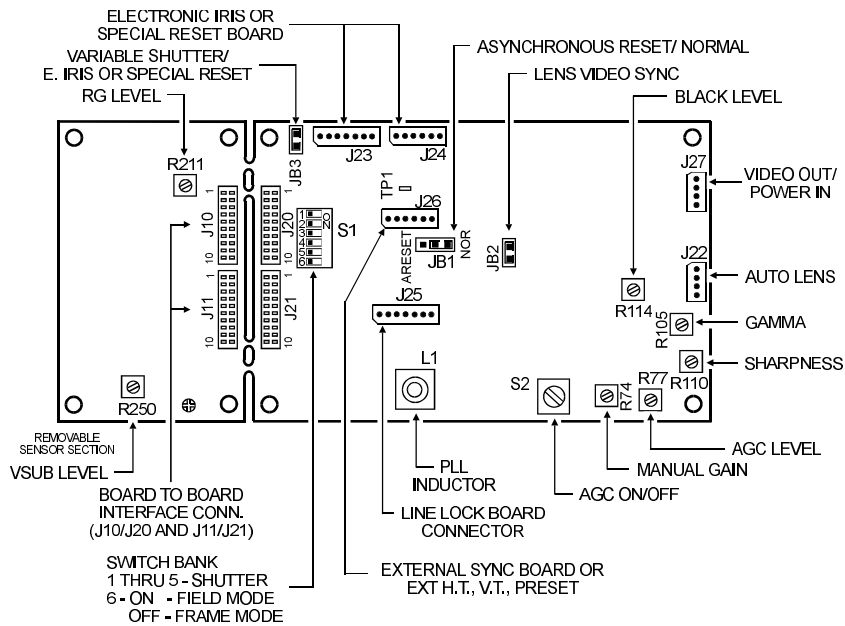

REF DESIG	NAME	FUNCTION
<b>MAIN BOARD</b>		
JB1	ARESET/NOR	Selects whether camera operates in asynchronous reset mode or normal mode
JB2	Lens Video Sync	Jumper is installed to provide sync on the auto-iris lens video signal
JB3	Variable Shutter/E. Iris or Special Reset	Jumper is installed for standard operation in variable shutter mode. Jumper must be removed before an option board can be installed onto J23 and J24. (Electronic Iris or Special Reset (integration) boards plug onto J23 and J24)
R74	Manual Gain	Sets gain of camera through a 20 dB range when the Agc On/Off switch (S2) is in OFF position
R105	Gamma	Sets gamma through a range of 0.45 to 1.0
R110	Sharpness	Rotating clockwise increases apparent contrast of scene by enhancing black/white and white/black transitions
R114	Black Level	Sets the level of black in the video, typically to 7.5 IRE units above blanking level
S1	DIP Switch Bank	Five DIP switches to select shutter speed or (in field mode) integration. Switch 6 selects field or frame mode. Switches must be set to 1/10,000 for either the optional electronic iris board or the special reset board to operate. See S1 Switch Settings table for a listing of switch positions.
S2	Agc On/Off	Selects whether agc controls camera gain or whether the Manual Gain potentiometer (R74) sets a fixed gain for the camera
TP1	Clock Test	Test point for clock frequency at pin 63 (XCK) of U5 (EIA, 28.6363 MHz, CCIR, 28.3750 MHz)
<b>LINE LOCK BOARD</b>		
JB10	0/180 jumper	Provides phase change of line lock reference by 180 degrees
R19	Line Phase	Provides a fine adjustment for control of phase reference
TP10	None	Test point for reference signal at input to phase detector
<b>EXTERNAL SYNC (GENLOCK) BOARD</b>		
JB1	Termination/ High	Selects either 75 ohm termination or a high input impedance for the external sync being applied. If the camera is at the end of a cable this jumper must be set to 75 ohm. If the camera is mid cable, as in a loop-through arrangement, the jumper must be set to high.
<b>SPECIAL RESET (INTEGRATION) BOARD</b>		
JB1	Start-Stop/ Special-Reset	When this jumper is positioned to start/stop, the negative-going edge of two separate pulses begins and ends the integration period. With the jumper in special reset position, the negative-going edge of a pulse begins integration and the subsequent positive-going edge of that pulse ends it. (Note: 1/10,000 shutter speed must be selected on main board DIP switch S1 for special reset to operate)
JB2	Negative / positive	Determines whether the grab pulse output at J34-1 is a negative-going pulse (from +5 V dc to zero volts) or a positive-going pulse (from zero volts to +5 volts)
<b>DC IRIS BOARD</b>		
R11	Iris Level	Sets the lens iris opening when viewing a standard test pattern or other controlled condition

REF DESIG	NAME	FUNCTION
<b>ELECTRONIC IRIS BOARD</b>		
JB1	E. Iris ON/OFF	Setting jumper to ON turns the electronic iris board on. When set to OFF, the board defaults to 1/60 (1/50) (Note: 1/10,000 shutter speed must be selected on main board DIP switch S1 for the electronic iris board to operate)
R19	DC	With jumper JB1 (E. Iris ON/OFF) positioned to OFF and 85 IRE units of 50% APL video out of the camera at J27-4, adjust R19 for 0.0 V dc between TP1 and TP2
TP1	-	Test point for setting R19
TP2	-	Test point for setting R19
TP3	-	Test point that when grounded initiates 1/10,000 shutter speed

*Note: Adjustments and jumpers listed in this table may require changes in the field due to installation requirements or to the camera application. Making any adjustment not listed in this table could render the camera inoperable until a complete test-bench setup is performed with instruments. This would require step-by-step procedures found in the Maintenance Manual (6X-960). Use care when making an adjustment in this table to ensure that no other control is accidentally adjusted.*

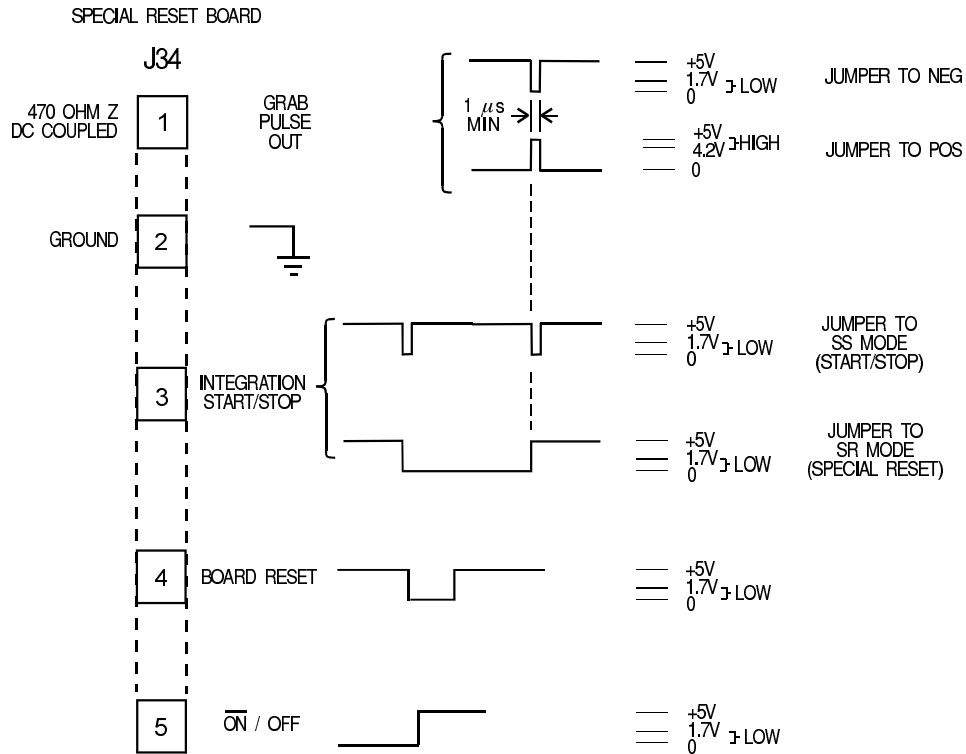

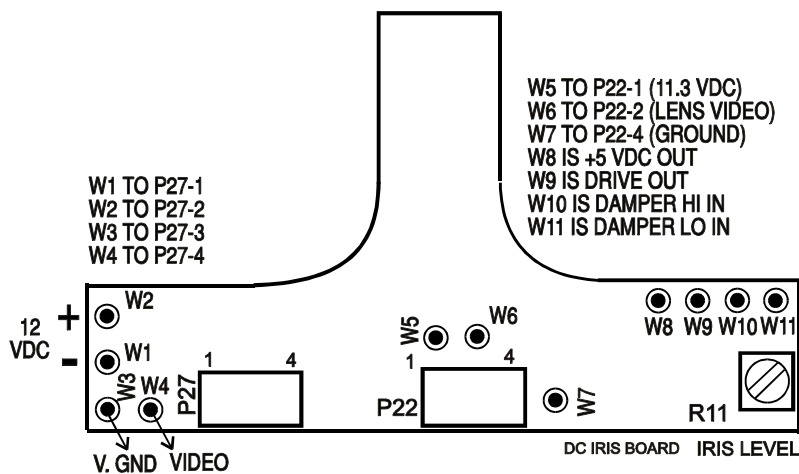
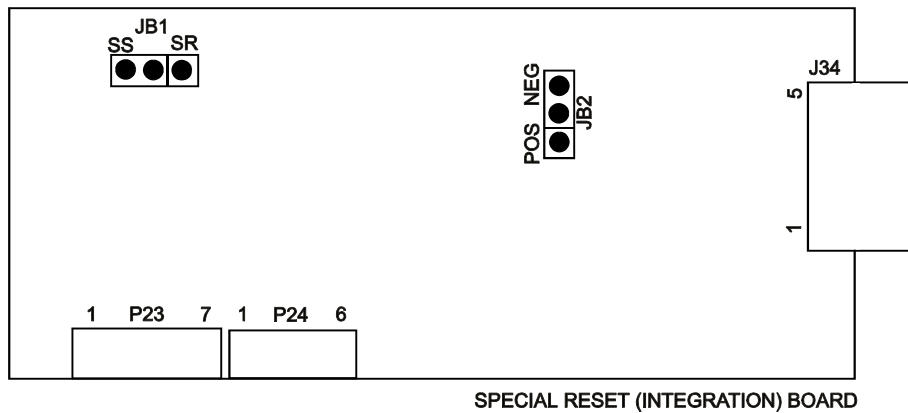
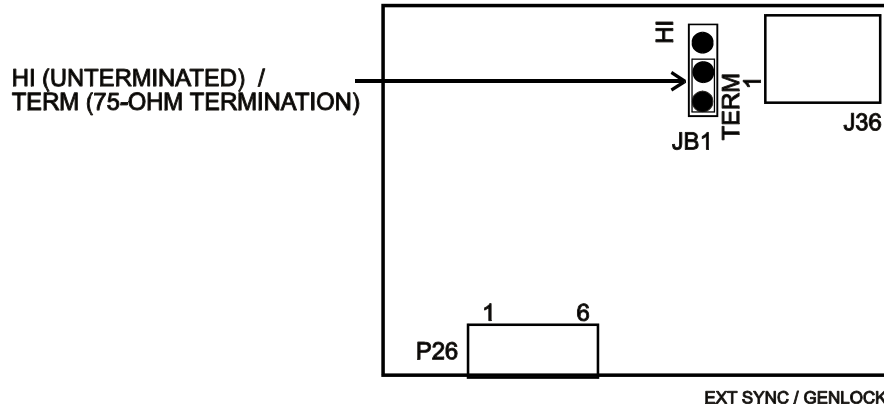
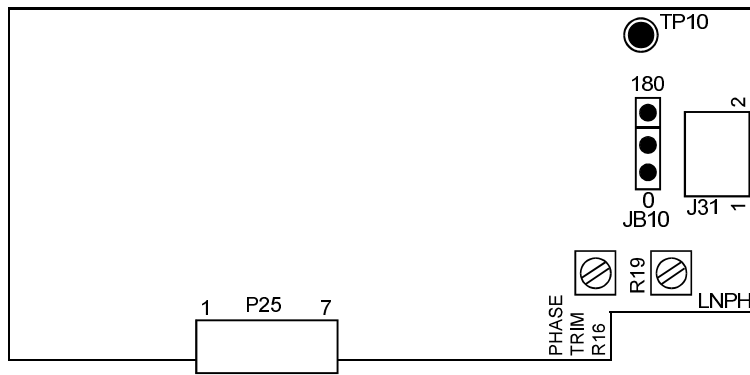

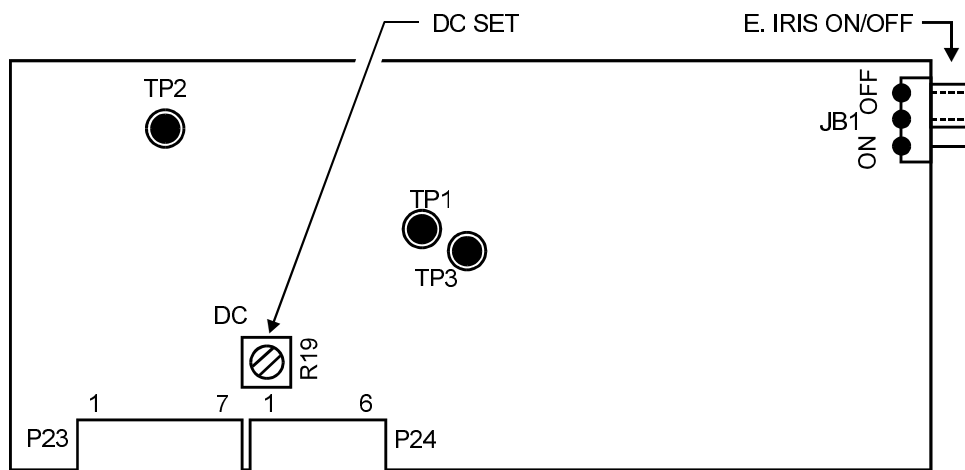

**WARRANTY**

Please refer to the Cohu website for product warranty information:  
[www.cohu-cameras.com](http://www.cohu-cameras.com)

Revision History		
Revision	Date	Comments
Rev C	04/25/2011	<ul style="list-style-type: none"> <li>This manual has been revised to comply with the latest engineering requirements. See ECO 030972 for the list of changes.</li> </ul>